

Kidde Engineered Fire Suppression System

Designed for use with 3M™ Novec™ 1230 Fire Protection Fluid



Effective: June 2015
K-45-9070

3-Way Directional Ball Valve Data Sheet

FEATURES

- *UL Listed, ULC Listed, and FM Approved for use with Novec 1230 Systems*
- *Cost-Effective Option for Protecting Multiple Hazards*
- *Pneumatic Operation Using Nitrogen Pilot Cylinder*
- *3-Way Valve Comes Pre-Assembles with Pneumatic Actuator; Optional Solenoid Available*
- *Nickel Plated Carbon Steel*
- *Low Loss Three Port Design*

DESCRIPTION

The Kidde Engineered Fire Suppression System designed for use with 3M™ Novec™ 1230 Fire Protection Fluid, offers the use of directional valves for protection of multiple hazards from one central storage bank of agent. When the same set of cylinders are used to protect different hazards, 3-Way Directional Valves may be included in the system. Since only one system (i.e., distribution piping and nozzles) can be entered and calculated at one time, it is necessary to create separate projects (.flc files) for each configuration. With respect to the directional valves, separate objects are used for a given valve size depending on the orientation of the valve. An “open” valve is used to allow agent to flow through the side (branch) outlet of the valve, and a “closed” valve would be used to allow agent to flow through the run outlet of the valve. When working with multiple files, the user should ensure that the type, diameter and length of any pipes common to more than one project file are identical. The pipe locking feature is useful here. In addition, the agent quantity per cylinder shall be identical.

Note: Per NFPA 2001–In sections where a valve arrangement introduces sections of closed piping, such sections shall be equipped with pressure relief devices, or the valves shall be designed to prevent entrapment of liquid. For pressure relief of manifold arrangements using directional valves, use a safety outlet (P/N 844346).

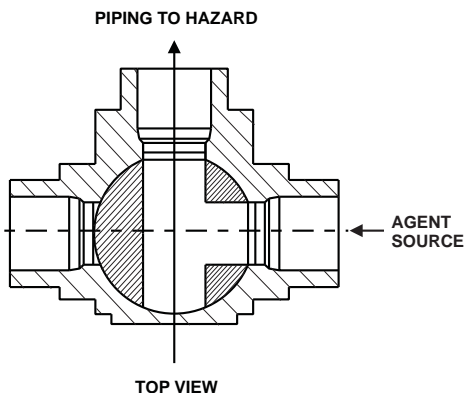
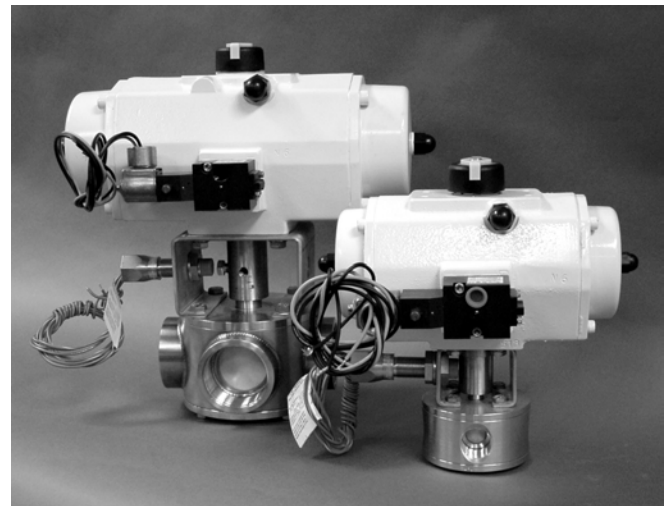

Figure 1. L Flow Ball Position

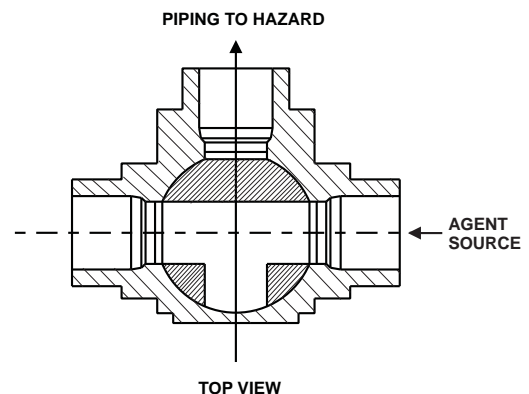

Figure 2. T Flow Ball Position

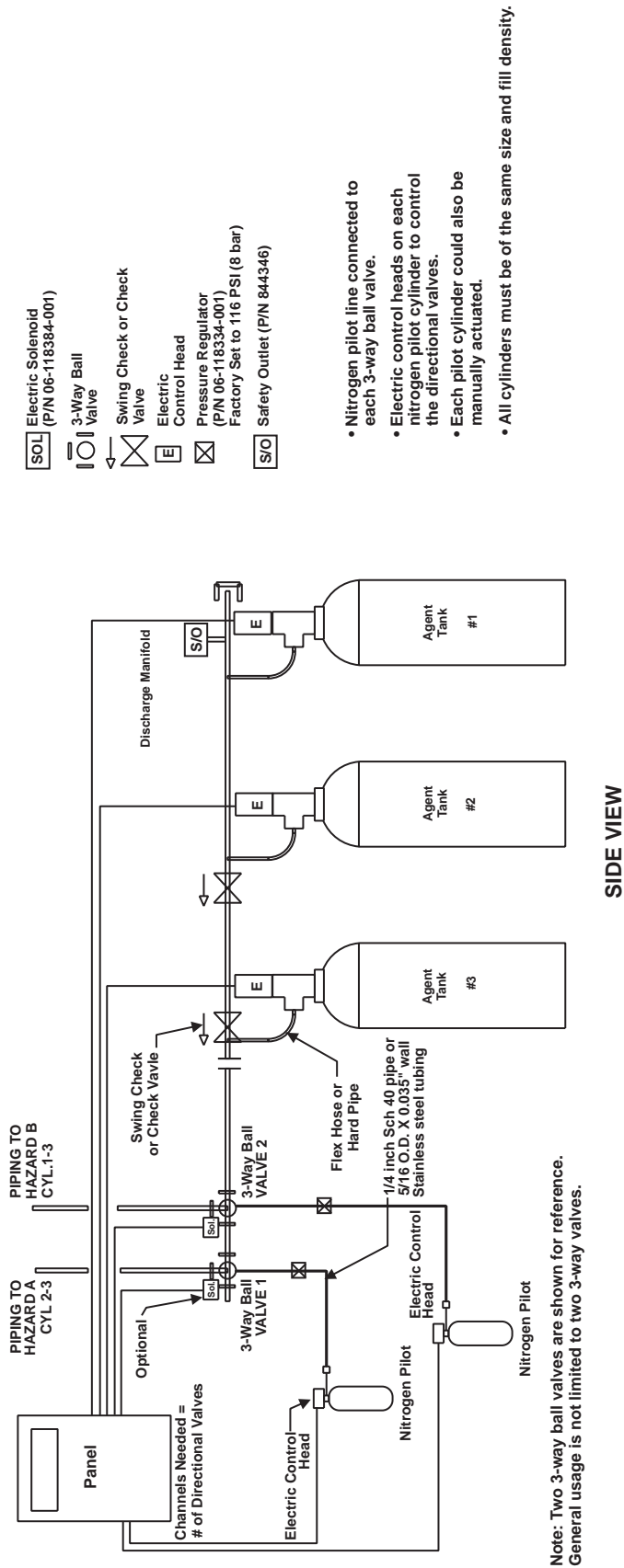
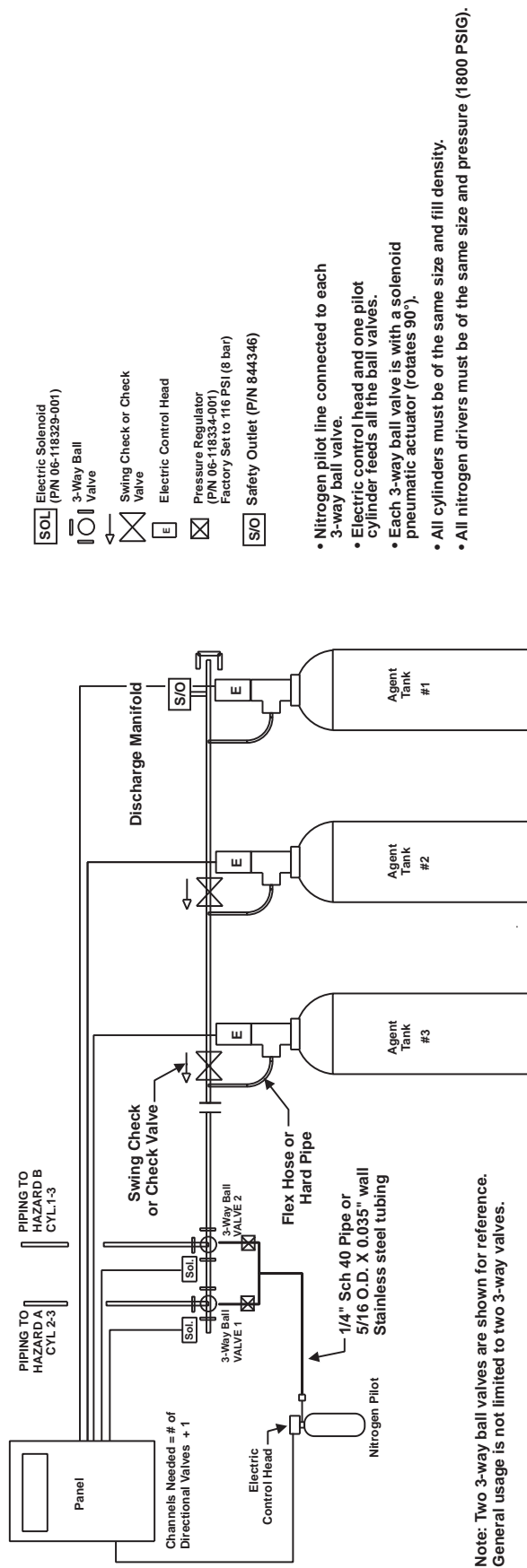

Figure 3. Arrangement 1: 3-Way Ball Valve with Pneumatic Actuator Dedicated for Each Directional Valve



SIDE VIEW

Figure 4. Arrangement 2: 3-Way Ball Valve with Pneumatic Actuator Controlled by a 24 Vdc Solenoid

Note: Two 3-way ball valves are shown for reference. General usage is not limited to two 3-way valves.

OPERATION

Note: Figure 3 illustrates Arrangement 1 which uses nitrogen pilot actuation for each 3-Way Directional Valve. Figure 4 illustrates Arrangement 2 which uses a single nitrogen pilot cylinder to actuate only one of a series of 3-Way Directional Valves.

A nitrogen pilot line is connected to each 3-Way Directional Valve. An electric control head is installed on each nitrogen pilot cylinder to actuate and release the nitrogen, which, in turn, pneumatically opens the valve. The nitrogen pilot line must be installed with a pressure regulator. The nitrogen line is then installed into the pneumatic solenoid (P/N 06-118384-001) that is attached to the pneumatic actuator. The pneumatic solenoid acts as a gate valve; when the signal is received from the panel to open the pneumatic solenoid, the pressure is then allowed to pass through the pneumatic actuator, which thereby turns the valve to the 90° "Open" orientation.

Table 1: 3-Way Directional Valve

Ball Valve Size	Maximum Number From One Pilot Cylinder	Maximum Tubing 5/16 in. x 0.035 in. Weight	Maximum 1/4 in. Schedule 40 Pipe
4 in.	3	200 ft.	100 ft.
3 in.	5	200 ft.	100 ft.
2 in.	8	200 ft.	100 ft.
1-1/2 in.	8	200 ft.	100 ft.
1-1/4 in.	8	200 ft.	100 ft.
1 in.	8	200 ft.	100 ft.
3/4 in.	8	200 ft.	100 ft.
1/2 in.	8	200 ft.	100 ft.



The pneumatic actuator and pneumatic solenoid are rated for a pressure of 115 to 150 PSI (6.89 to 10.34 bar gauge). A pressure regulator must be installed in line to reduce the nitrogen pressure that is being released from the pilot cylinder. Pressure regulator P/N 06-118334-001 is factory set to 116 PSI (8 bar gauge).

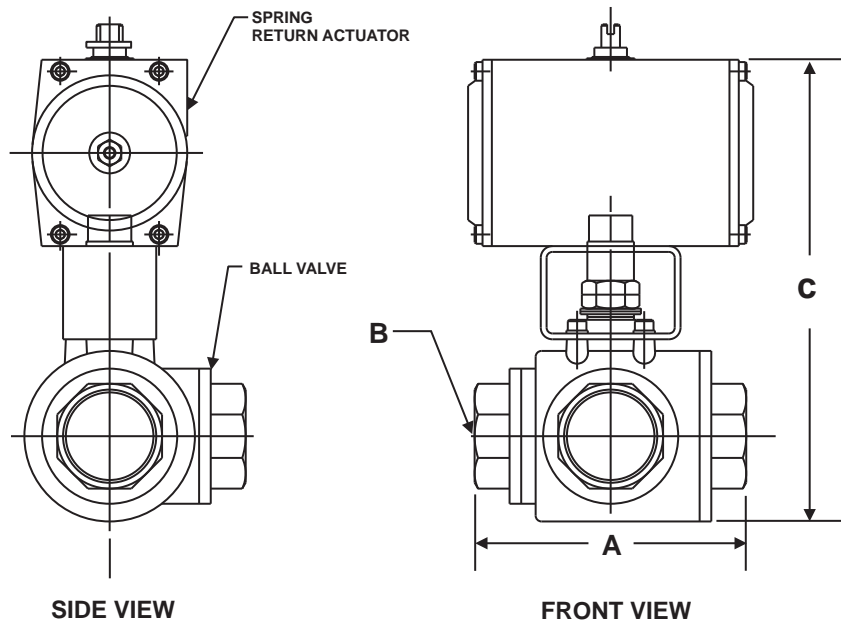

Figure 5. 3-Way Directional Ball Valves
(See Table 2 for more information)

Table 2: 3-Way Directional Ball Valve Specifications

Part Number without Solenoid	Part Number with Solenoid	Nominal Size	Dimensions			Valve Working Pressure	Breakaway Touque
			A*	B*	C*		
45-220027-001	45-220030-001	1/2 in.	3.50 in.	0.688	11.23 in.	400 PSIG	200 in.-lb.
45-220027-002	45-220030-002	3/4 in.	4 in.	0.824	12.13 in.	400 PSIG	250 in.-lb.
45-220027-003	45-220030-003	1 in.	4 in.	1.000	12.13 in.	400 PSIG	250 in.-lb.
45-220028-001	45-220031-001	1-1/4 in.	6 in.	1.380	13.69 in.	400 PSIG	500 in.-lb.
45-220028-002	45-220031-002	1-1/2 in.	6 in.	1.500	13.69 in.	400 PSIG	500 in.-lb.
45-220028-003	45-220031-003	2 in.	7.25 in.	2.000	15.66 in.	400 PSIG	800 in.-lb.
45-220029-001	45-220032-001	3 in.	11 in.	3.000	21.44 in.	400 PSIG	3000 in.-lb.
45-220029-002	45-220032-002	4 in.	13.38 in.	4.000	24.68 in.	400 PSIG	4300 in.-lb.

* Note: Dimensions are approximate for the entire assembly

Table 2: 3-Way Directional Ball Valve Specifications (cont.)

Part Number without Solenoid	Part Number with Solenoid	Nominal Size	Material	Inlets	Port	T-Flow Equivalent Length	L-Flow Equivalent Length
45-220027-001	45-220030-001	1/2 in.	ENP Carbon Steel	NPT	Full	0.19 ft.	1.83 ft.
45-220027-002	45-220030-002	3/4 in.	ENP Carbon Steel	NPT	Full	0.37 ft.	3.61 ft.
45-220027-003	45-220030-003	1 in.	ENP Carbon Steel	NPT	Full	1.48 ft.	9.31 ft.
45-220028-001	45-220031-001	1-1/4 in.	ENP Carbon Steel	NPT	Full	1.19 ft.	11.65 ft.
45-220028-002	45-220031-002	1-1/2 in.	ENP Carbon Steel	NPT	Full	1.77 ft.	12.08 ft.
45-220028-003	45-220031-003	2 in.	ENP Carbon Steel	NPT	Full	1.82 ft.	13.75 ft.
45-220029-001	45-220032-001	3 in.	ENP Carbon Steel	Victaulic	Full	5.00 ft.	26.01 ft.
45-220029-002	45-220032-002	4 in.	ENP Carbon Steel	Victaulic	Full	7.73 ft.	32.42 ft.

Table 3: Pneumatic Actuator Specifications

Part Number without Solenoid	Part Number with Solenoid	Nominal Size	Actuator Mechanism	Actuator Type	Actuator Volume	Actuator Torque	Working Pressure	Maximum Pressure
45-220027-001	45-220030-001	1/2 in.	Rack and Pinion	Spring Return	30 in. ³	865 in.-lb.	115 PSIG	145 PSIG
45-220027-002	45-220030-002	3/4 in.	Rack and Pinion	Spring Return	30 in. ³	865 in.-lb.	115 PSIG	145 PSIG

Table 3: Pneumatic Actuator Specifications

Part Number without Solenoid	Part Number with Solenoid	Nominal Size	Actuator Mechanism	Actuator Type	Actuator Volume	Actuator Torque	Working Pressure	Maximum Pressure
45-220027-003	45-220030-003	1 in.	Rack and Pinion	Spring Return	30 in. ³	865 in.-lb	115 PSIG	145 PSIG.
45-220028-001	45-220031-001	1-1/4 in.	Rack and Pinion	Spring Return	61 in. ³	1877 in.-lb	115 PSIG	145 PSIG
45-220028-002	45-220031-002	1-1/2 in.	Rack and Pinion	Spring Return	61 in. ³	1877 in.-lb	115 PSIG	145 PSIG
45-220028-003	45-220031-003	2 in.	Rack and Pinion	Spring Return	61 in. ³	1877 in.-lb	115 PSIG	145 PSIG
45-220029-001	45-220032-001	3 in.	Rack and Pinion	Spring Return	189 in. ³	4887 in.-lb	115 PSIG	145 PSIG
45-220029-002	45-220032-002	4 in.	Rack and Pinion	Spring Return	299 in. ³	8288 in.-lb	115 PSIG	145 PSIG

COMPONENTS

3-WAY DIRECTIONAL VALVES (P/N 45-2200XX-00X)

The 3-Way Directional Valves are used for applications where a single bank of cylinders are used to protect multiple hazards (see the Design, Installation, Operation, and Maintenance Manual P/N 45-N1230M-001, for more information). The directional valves have a factory installed pneumatic, spring loaded actuator and range in sizes from 1/2 inch to 4 inches. The directional valves can be installed in the network, provided that they are accounted for in the software calculation. Refer to Figure 5, and Table 2 for more information.

PNEUMATIC SOLENOID (P/N 06-118384-001)

The pneumatic solenoid is a cost-effective component that is used with the pneumatic actuators and 3-Way Directional Valves. With the solenoid, one nitrogen pilot cylinder can be used for multiple directional valves. The solenoid is factory set to normally closed. A signal from the panel opens the solenoid that is attached to the appropriate pneumatic actuator. Pressure is then allowed to pass through the solenoid and open the 3-Way Directional Valve.

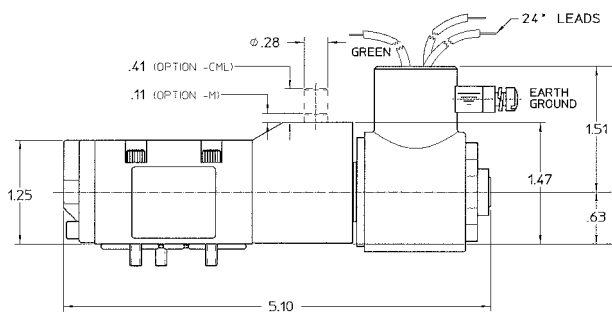

Figure 6. Pneumatic Solenoid

PRESSURE REGULATOR (P/N 06-118334-001)

The pressure regulator is used up stream of the pneumatic solenoid to regulate the nitrogen pressure to 116 PSI (8 bar gauge) prior to operating the pneumatic actuator on the directional valve.

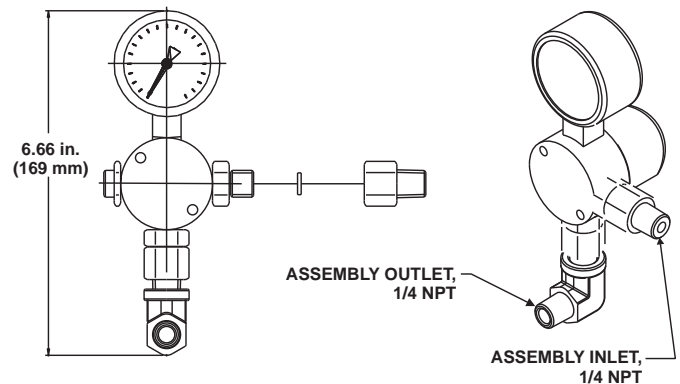

Figure 7. Pressure Regulator

COMPONENT SPECIFICATIONS

Table 4: Pneumatic Solenoid Specification

Description	Measurement
Pressure Range	15 to 115 PSIG
Voltage Rating	24 Vdc
Power Consumption (DC)	7 W
Power Consumption (AC)	6 W
Coil	CG5

Table 4: Pneumatic Solenoid Specification

Description	Measurement
Weight	0.80 lb.
Ports	1/4 in. NPT
Includes:	Locking Manual Override Button

Table 5: Pressure Regulator Specifications

Part Number	Description
06-118334-001	Pressure Regulator

INSTALLATION

All Kidde Engineered System equipment must be installed to facilitate proper inspection, testing, manual operation, recharging and any other required maintenance as may be necessary. Equipment must not be subject to severe weather conditions or mechanical, chemical, or other damage that could render the equipment inoperative. Equipment must be installed in accordance with NFPA Standard 2001, current edition.

The Kidde Engineered System cylinder/valve assemblies must be handled, installed and serviced in accordance with the instructions contained in this Section and Compressed Gas Association (CGA) pamphlets C-1, C-6 and P-1. CGA pamphlets may be obtained from: Compressed Gas Association, 1235 Jefferson Davis Highway, Arlington, VA 22202. Failure to follow these instructions can cause Kidde Engineered System cylinders to violently discharge, resulting in severe injury, death and/or property destruction.



WARNING

PRESSURE ACTUATION PIPE

The pressure actuation pipe must be 1/4-inch Schedule 40 or 80 pipe or 5/16 in. O.D. x 0.035 in. wall stainless steel tubing. Actuation lines shall be protected against crimping and mechanical damage (per NFPA 2001, Section 2-3.4.2). The pipe or tubing must be routed in the most direct manner with a minimum number of fittings. Pipe and fittings must be in accordance with the requirements listed in the Design, Installation, Operation, and Maintenance Manual (P/N 45-N1230M-001). Fittings can be flared or compression type. The pressure-temperature ratings of the fitting manufacturer must not be exceeded.

DIRECTIONAL VALVES WITH PNEUMATIC ACTUATORS AND SOLENOIDS

Note: Flanged fittings are to be installed per ANSI B16.5.

1. Gather the required parts for the chosen directional system based upon the number of 3-Way Directional Valves needed and the actuation scheme desired.
 - Single pilot cylinder actuation requires one pilot cylinder, actuation hoses (number of hoses equals two times the number of directional valves), electric control head, the directional valves with solenoid pneumatic actuators and a pressure regulator.
 - Multiple pilot actuation requires pilot cylinders (number of pilot cylinders equals one times the number of directional valves), actuation hoses (number of hoses equals one times the number of directional valves), electric control heads (number of control heads equals one times the number of directional valves), directional valves with pneumatic actuators and a pressure regulator.

Note: The pressure regulator must be located within 12 in. of the solenoid and pneumatic actuator.

2. Ensure that all directional valves are in the “straight through” position before installation (the T-port in the valve should be open on both ends with the side port closed).

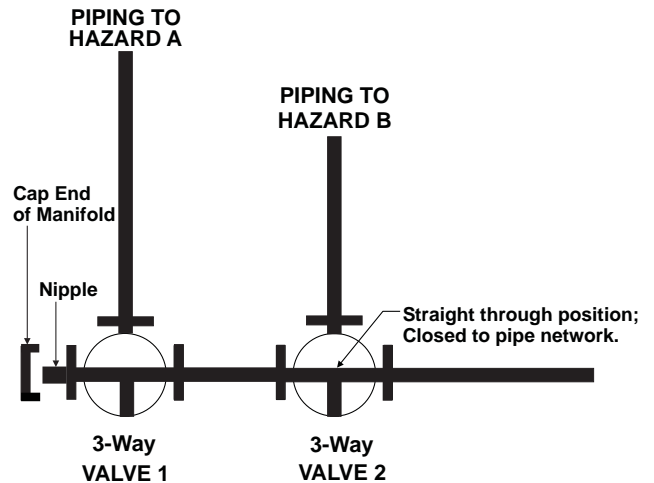

Figure 8. Straight Through Orientation

The directional valve must be installed so that the 90° turn of the actuator brings the T-port open on the side branch and the end of the valve that faces the Novec 1230 fluid source. The arrow on the valve must be pointed in the direction of the flow.

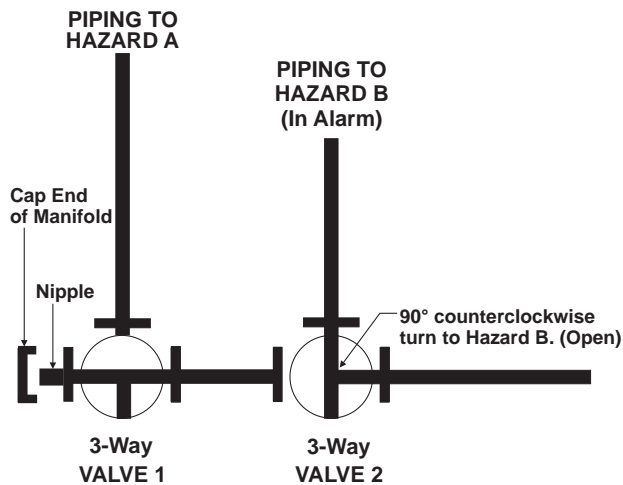

Figure 9. 90° Counterclockwise Orientation (Open)

3. Connect the actuators on the directional valves to the pneumatic source in one of two ways:
 - For pilot cylinder actuation, all directional valves must have a 24 Vdc solenoid (P/N 06-118384-001) and a 24 Vdc connection from the control panel.
 - Connect the pilot cylinder to the second pressurization port of the solenoid actuator using the actuation line.
 - Connect each of the solenoids and the electric control head to the control panel so that the electric control head fires and the correct directional valve operates for the desired hazard.
 - Test each hazard with the control panel by listening for the solenoid click at each directional valve.
 - Reconnect all electrical connections.
 - Attach an electric control head to the pilot cylinder (being sure it is set before installation).
4. Set the control panel to provide a 17.0 second delay between the firing of the pilot cylinders for the directional valves and the firing of the Kidde Engineered System (see Table 6). This delay provides sufficient time for the valves to fully open before the system is discharged.

Table 6: Directional Valve Data

Part Number Without Solenoid	Part Number With Solenoid	Description	Time Delays Required to Open
45-220027-001	45-220030-001	1/2 in. NPT	17 secs.
45-220027-002	45-220030-002	3/4 in. NPT	17 secs
45-220027-003	45-220030-003	1 in. NPT	17 secs

Table 6: Directional Valve Data

Part Number Without Solenoid	Part Number With Solenoid	Description	Time Delays Required to Open
45-220028-001	45-220031-001	1-1/4 in. NPT	17 sec.
45-220028-001	45-220031-002	2 in. NPT	17 sec.
45-220028-002	45-220031-003	1-1/4 in. NPT	17 sec.
45-220029-001	45-220032-001	3 in. Victaulic	17 sec.
45-220029-002	45-220032-002	4 in. Victaulic	17 sec.

Note: 17 seconds is the maximum time needed for the 4 in. ball valve to open under pressure.

SYSTEM RELEASE CONTROL CONFIGURATION

IMPORTANT — The information in this paragraph refers to circuits and wiring employed on PEGAsys panels; specific Kidde Engineered System configurations and/or other programmable panels may require different wiring and/or panel-to-panel connections.

A maximum of eight suppression hazards and a maximum of eight electrically actuated cylinders are allowed per system. Multiple panels may be employed to control and release the system. The smallest Kidde Engineered System system configuration would require a minimum of four release circuits.

Regardless of configuration, the following sequence of activation must be adhered to:

1. When a call for suppression is received by the panel for a specific suppression zone, the appropriate selector valve solenoid and nitrogen pilot control head must activate within 0.5 seconds of each other.
2. Six to ten seconds after the selector valve solenoid and nitrogen pilot control head actuates, the appropriate control heads must activate. After any hazard activates, no other activation is allowed until the system is serviced. Failure to follow these sequences could result in system malfunction.



PEGAsys or other programmable FM Approved (for FM insured installations)/ UL Listed compatible fire alarm suppression control panel

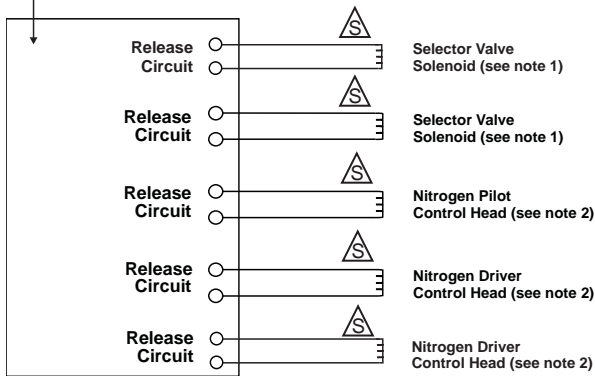

Denotes Supervised Circuit

Figure 10. Typical Single Panel System Release Circuit Wiring (See Notes Below)

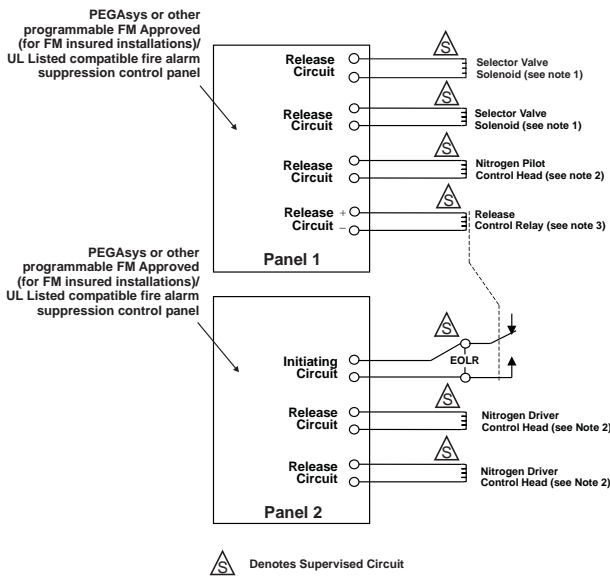

Denotes Supervised Circuit

Figure 11. Typical Multiple Panel System Release Circuit Wiring (See Notes Below)

Notes:

1. Must use Pneumatic Solenoid (P/N 06-118384-001). Ratings: 24 Vdc, 11.0 W; 2.0 Vdc minimum dropout.
2. Must use 24 Volt DC control head. The fire alarm suppression panel release circuit must be capable of supplying a minimum of 24 Vdc @ 2.8 Amps for 30 milliseconds for control head P/N 890181, and a minimum of 24 Vdc @ 0.5 Amps continuous for control head P/N 81-100000-001.
3. Release control relays are only required if the Agent Cylinder solenoids are released by a separate panel. Relays employed must be electrically compatible with the release circuit output characteristics for both pull-in and dropout voltages.
4. A means of manual release of the system shall be provided. Manual release shall be accomplished by a mechanical manual release, or by an electrical manual release, when the control equipment monitors the battery voltage level of the standby battery supply and will provide a low battery signal. The release shall cause simultaneous operation of automatically operated valves controlling agent release and distribution.

* Refer to the PEGAsys Installation, Operation and Maintenance Manual (P/N 76-100016-001) for complete details.



WARNING

The referenced control heads and solenoids are compatible with PEGAsys panels. The use of other panels to operate these control heads and solenoids has not been verified and could result in system malfunction.

ORDERING INFORMATION

Part Number		Description
Valves		
Without Solenoid	With Solenoid	
45-220027-001	45-220030-001	3-Way Directional Valve, 1/2 inch
45-220027-002	45-220030-002	3-Way Directional Valve, 3/4 inch
45-220027-003	45-220030-003	3-Way Directional Valve, 1 inch
45-220028-001	45-220031-001	3-Way Directional Valve, 1-1/4 inch
45-220028-002	45-220031-002	3-Way Directional Valve, 1-1/2 inch
45-220028-003	45-220031-003	3-Way Directional Valve, 2 inch
45-220029-001	45-220032-001	3-Way Directional Valve, 3 inch
45-220029-001	45-220032-002	3-Way Directional Valve, 4 inch
Pneumatic Solenoid (Note: Part of Valve Assembly. Use below for spare parts only.)		
06-118384-001		Pneumatic Solenoid, 24 Vdc
Pressure Regulator		
06-118334-001		Pressure Regulator, 116 PSI (8 bar)

Kidde is a registered trademark of Kidde-Fenwal, Inc.
 3M and Novec are trademarks of 3M.
 All other trademarks are property of their respective owners.

This literature is provided for informational purposes only. KIDDE-FENWAL, INC. assumes no responsibility for the product's suitability for a particular application. The product must be properly applied to work correctly.
 If you need more information on this product, or if you have a particular problem or question, contact KIDDE-FENWAL, INC., Ashland, MA 01721. Telephone: (508) 881-2000.

